



Handling & Transport Equipment

Trolley Lifts

2

Highlights of the transportable lifting tables

Our offer

- Adjustable lowering speed thanks to an adjustable hydraulic valve operated from the handle on the scissor-type lifting truck.
- Quiet and smooth transportation thanks to rubber rollers with ball-bearings, for up to 250 kg, and polyurethane rollers, for up to 750 kg.
- Easy to maneuver and position.
- The scissor-type lifting truck version, with a lifting capacity of 150 kg, comes with foldable handrail for easy transportation as standard.
- Parking brake
- Pressure control valve for preventing overloading.
- PRAKTIKUS comes with maintenance-free bearings, hard chrome-plated piston rod and chrome-plated frame

Your advantage

High level of performance

High standard of safety

Long lasting

HP-E 0412 PRAKTIKUS

Electrical drive lifting and manual moving

This superior quality version of the PRAKTIKUS can be effortlessly controlled due to the electro-hydraulic lifting system powered by a 12 V 28 Ah battery! This highly maneuverable assistant easily lifts loads up to 400 kg to a maximum lifting height of 1,16 m. Precise control of lowering speed is provided by an adjustable hydraulic valve at the control handle. The quality of the electro-hydraulic PRAKTIKUS is also shown during battery charge – thanks to the integrated 230 V charging unit. Its robust construction, with chrome-plated chassis and hard-chrome plated piston rods completes the package.



HP 0285, HP 0212, HP 0485, HP 0412 PRAKTIKUS

Manual moving and manual lifting

This mobile, sturdy and lightweight your personal "work-assistant" is ideal! Optimum lifting and transporting of all kinds of loads up to 400 kg and 1,2 m lifting height. Ensuring maximum stability the sturdy chassis is equipped with 2 fixed and 2 steering rollers and a wheel brake. Take your individual choice out of four models – choose your individual platform height and lifting capacity to suit your needs and allowing efficient work. The platform of the PRAKTIKUS can be smoothly raised and lowered by means of a hydraulic foot pump equipped with a fold-up pedal. Exact control of the lowering speed is provided by an adjustable hand-wheel-operated hydraulic valve. A long and reliable service life is guaranteed thanks to its robust construction, chrome-plated chassis and hard-chromed piston rods.



Trolley Lifts

2

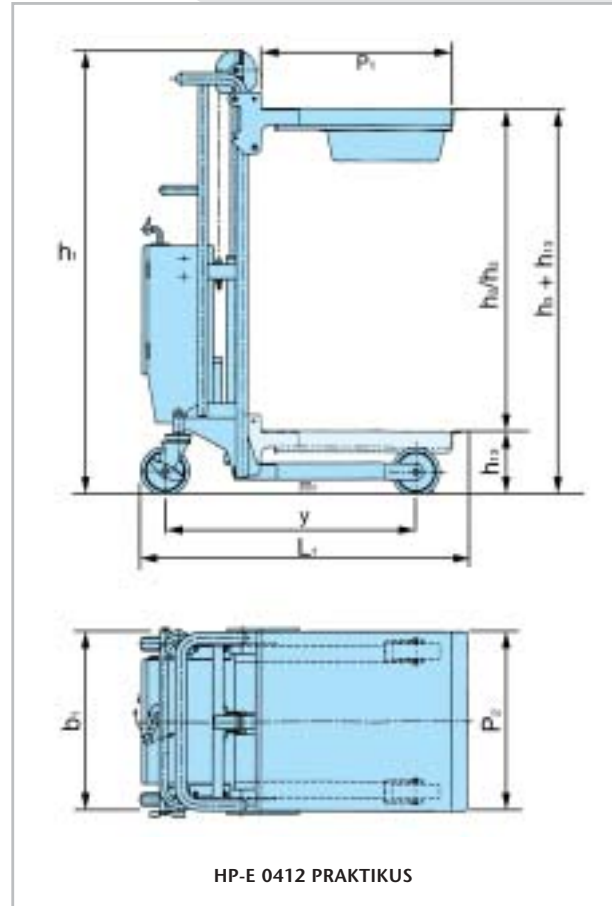
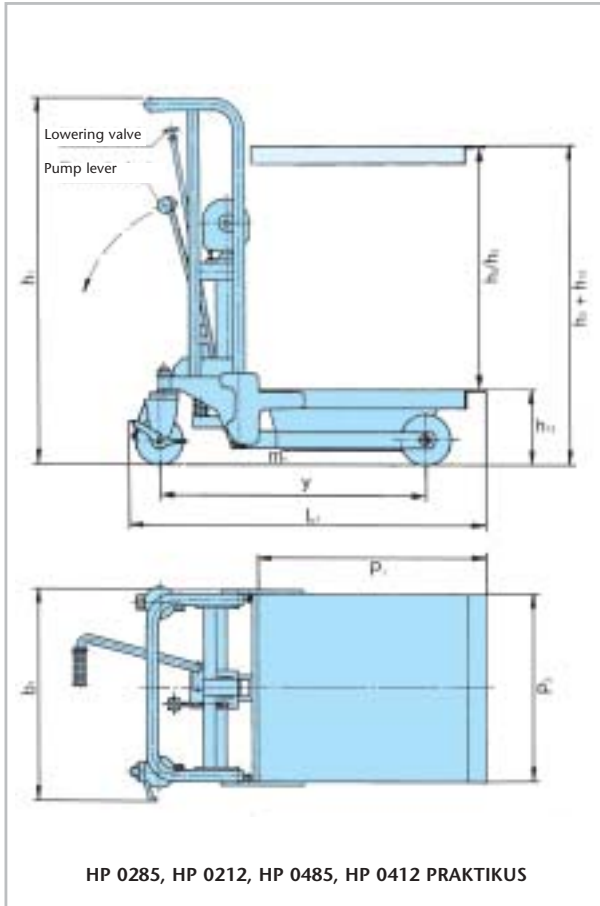

Type		HP 0285	HP 0212	HP 0485	HP 0412	HP-E 0412
Art. No.		040008776	040008777	040008778	040008779	034586044
Lifting capacity in kg		200	200	400	400	400
Weight in kg		65	70	66	71	95
Rollers*		SR / SR	SR / SR	SR / SR	SR / SR	SR / PUR
Roller size front in mm		150 x 45	150 x 45	150 x 45	150 x 45	130 x 65
Roller size rear in mm		150 x 45	150 x 45	150 x 45	150 x 45	130 x 40
Total no. of rollers front/rear		2 / 2	2 / 2	2 / 2	2 / 2	2 / 2
Total height in mm	h ₁	960	1310	960	1310	1355
Free lift in mm	h ₂	650	1000	650	1000	1000
Lifting height in mm	h ₃	650	1000	650	1000	1000
Max. height of platform in mm	h ₃ + h ₁₃	850	1200	850	1200	1160
Min. height of platform in mm	h ₁₃	200	200	200	200	160
Total length in mm	L ₁	1037	1037	1037	1037	1060
Total width in mm	b ₁	590	590	590	590	600
Platform length in mm	P ₁	650	650	650	650	650
Platform width in mm	P ₂	550	550	550	550	600
Floor/ground clearance in mm	m ₁	50	50	50	50	35
Wheelbase in mm	y	785	785	785	785	774
Lifting height per pump stroke in mm		23	23	23	23	-
Lifting time in secs		-	-	-	-	7-12
Lowering time in secs		-	-	-	-	5-20

* Solid Rubber (SR), Polyamide (PA), Polyurethane (PUR), Steel (S), Vulkollan (VUL)



Handling & Transport Equipment

Scissors Lift Trolleys

2



HX 750

HX 150, HX 300, HX 500, HX 750 Scissors Lift Trolley
Manual drive and manual lifting

Sturdy and exceptionally individual. The technical features of the HX-series not only convince with its effortless lifting due to the hydraulic foot-pump but also with its adjustable hydraulic valve allowing the exact controlling of the lowering speed from the steering handle. There are four different models designed for fulfilling your individual lifting needs with lifting heights of 220 up to 1000 mm. Industry can benefit from a new set safety standard! The scissors lift trolleys offers both – safe operation and reliable cost-efficiency.



HX 150



HX 300

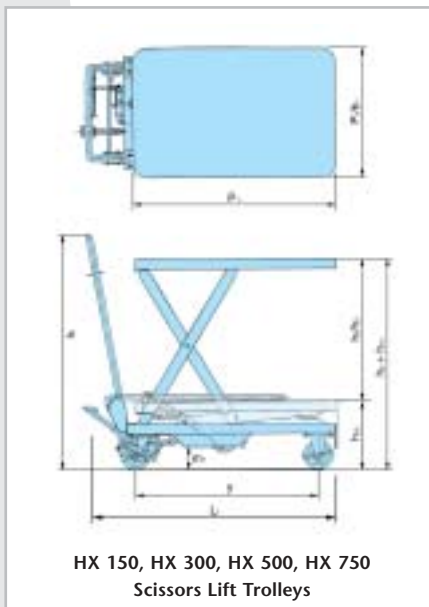

HX 150, HX 300, HX 500, HX 750
Scissors Lift Trolleys

Type		HX 150	HX 300	HX 500	HX 750
Art. No.		034600020	034600021	034600022	034600023
Lifting capacity in kg		150	300	500	750
Weight in kg		49	78	82	120
Rollers*		PUR/PUR	PUR/PUR	PUR/PUR	PUR/PUR
Roller size front in mm		100 x 36	128 x 40	128 x 40	147 x 50
Roller size rear in mm		100 x 36	128 x 40	128 x 40	147 x 50
Total no. of rollers front/rear		2 / 2	2 / 2	2 / 2	2 / 2
Total height in mm	h ₁	960	984	984	990
Free lift in mm	h ₂	500	595	595	580
Lifting height in mm	h ₃	500	595	595	580
Max. height of platform in mm	h ₃ + h ₁₃	720	880	880	1000
Min. height of platform in mm	h ₁₃	220	285	285	420
Total length in mm	L ₁	908	1093	1093	1330
Total width in mm	b ₁	450	500	500	600
Platform length in mm	P ₁	700	850	850	1000
Platform width in mm	P ₂	450	500	500	510
Floor/ground clearance in mm	m ₁	26	53	53	72
Wheelbase in mm	y	648	740	740	1020
Lifting height per pump stroke in mm		27	31	31	15

* Solid Rubber (SR), Polyamide (PA), Polyurethane (PUR), Steel (S), Vulkollan (VUL)



Scissors Lift Trolleys

2

HX-D 0350 Scissor Lift Trolley

Manual lifting, manual transportation

Robust with extended lift height. The HX-D scissor lift trolley takes you to the highest level of lifting functionality. This elegant lift trolley effortlessly handles lifting heights of 0,37 m to 1,3 m thanks to its double scissors. Just like the HX, the powerful double scissor version has polyurethane rollers for smooth and quiet transportation. Service-proven quality with a new dimension in performance.



HX-D 0350

Type		HX-D 0350
Art. No.		034600024
Lifting capacity in kg		350
Weight in kg		136
Rollers*		PUR/PUR
Roller size front in mm		128 x 40
Roller size rear in mm		128 x 40
Total no. of rollers front/rear		2 / 2
Total height in mm	h ₁	965
Free lift in mm	h ₂	930
Lifting height in mm	h ₃	930
Max. height of platform in mm	h ₃ + h ₁₃	1300
Min. height of platform in mm	h ₁₃	370
Total length in mm	L ₁	1140
Total width in mm	b ₁	500
Platform length in mm	P ₁	910
Platform width in mm	P ₂	500
Floor/ground clearance in mm	m ₁	31
Wheelbase in mm	y	817
Lifting height per pump stroke in mm		21

* Solid Rubber (SR), Polyamide (PA), Polyurethane (PUR), Steel (S), Vulkollan (VUL)

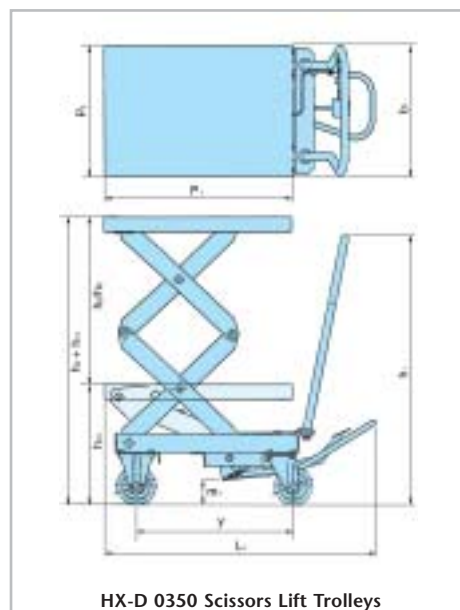

HX-D 0350 Scissors Lift Trolleys