



Lifting Tables

PROLINE Standard Lifting Tables

3



For further details of optional accessories please see page 53



Universal hydraulic lifting tables for the lifting of heavy machines or machinery parts. Space-saving pit installation along with extreme robustness, thanks to the use of wear resistant components.



silberblau / **LONGLIFE**

HTS-X PROLINE up to 2t

Standard lifting table with robust platform made of rigid, curved stud plates (either 6 mm thick/up to 500 kg capacity or 8 mm thick/over 500 kg capacity). Designed for the effort-saving lifting of heavyweight machinery with the long-term view in mind. Numerous superior technical features ensure both a high level of efficiency and a considerably longer service life. For example, the scissors bearings with lubricating possibility, which are extremely robust thanks to

their hardened, manganese phosphate/molykote-treated bearing surfaces. Plus items as the ball bearing rollers with permanent lubrication and reinforced, hardened running surfaces. This, and much more is provided in addition to a maximum lifting capacity of 2 metric tons. All this is standard at Pfaff-silberblau, and along with our short delivery times this is the key of our success. We will be pleased to inform you on further details.



PROLINE Standard Lifting Tables

The highlights of our standard lifting tables

Our offer

- Low resilience
- Lifting speed is nearly constant over the entire lift
- Lubricant-filled plain spherical roller bearings ensure a high level of efficiency
- None or only low pressure peaks prevent seal, valve and pump elements from wear
- Hydraulic cylinders with sealed plunger system avoid corrosion problems caused by air-intake
- Cylinder and scissor bearings are possible to lubricate
- Ball bearing rollers with permanent lubrication
- Platform made of rigid curved steel (6 mm thick/up to 500 kg capacity or 8 mm/over 500 kg capacity)
- The adjustable upper stroke limit switch is protected by being fitted under the platform.

Please ask for further options, such as higher lifting capacity or alternative platform sizes!

Your advantage

High level of handling performance

Long service life

High level of safety

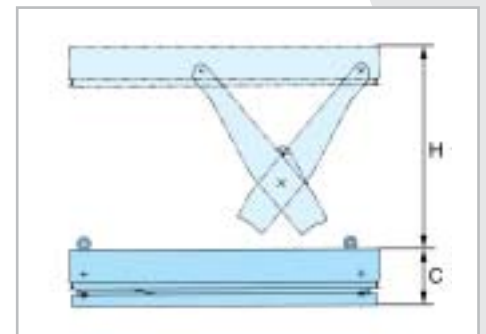
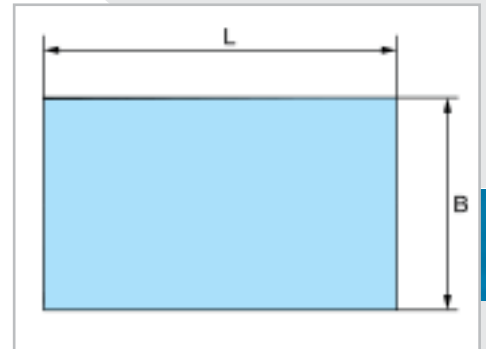

3

HTS-X PROLINE standard lifting tables

Art. No.	Lifting capacity t	Lift (H) m	Platform (L x B) m	Overall size (C) mm	Lifting time s	Motor power kW	Weight kg
034560003	0,5	0,8	1,30 x 0,8	240	13	1,1	353
034560004	0,5	0,8	1,30 x 1,0	240	13	1,1	388
034560006	0,5	1,0	1,50 x 0,8	240	18	1,1	386
034560007	0,5	1,0	1,50 x 1,0	240	18	1,1	432
034560008	0,5	1,3	2,00 x 0,8	280	22	1,1	440
034560009	0,5	1,3	2,00 x 1,0	280	22	1,1	554
034560013	1,0	0,8	1,30 x 0,8	240	13	1,1	353
034560014	1,0	0,8	1,30 x 1,0	240	13	1,1	395
034560016	1,0	1,0	1,50 x 0,8	240	18	1,1	390
034560017	1,0	1,0	1,50 x 1,0	240	18	1,1	430
034560020	1,0	1,3	2,00 x 0,8	280	22	1,1	530
034560021	1,0	1,3	2,00 x 1,0	280	22	1,1	553
034560023	2,0	0,8	1,30 x 0,8	240	26	1,1	399
034560024	2,0	0,8	1,30 x 1,0	240	26	1,1	443
034560025	2,0	1,0	1,50 x 0,8	240	35	1,1	443
034560026	2,0	1,0	1,50 x 1,0	240	35	1,1	515
034560028	2,0	1,0	1,50 x 1,4	240	35	1,1	646
034560029	2,0	1,3	2,00 x 0,8	280	44	1,1	580
034560030	2,0	1,3	2,00 x 1,0	280	44	1,1	643
034560031	2,0	1,3	2,00 x 1,4	280	44	1,1	830