



Lifting Tables

PROLINE & SILVERLINE Low Height Scissors Lifting Tables

3

When the effort-saving lifting of heavy-weight loads is the top requirement, the equipment needed is this extremely low design lifting table with its practical approach ramp that allows goods to roll conveniently right onto the platform.



silberblau DRIVEUP HTF-XG PROLINE up to 1,5t

This extremely low design low height scissor lifting table with closed platform requires no pit installation, this saves you a lot of work. The reason is a 800 mm long roll-on ramp, which allows fully-laden pallet lifters - or transport vehicles - to be moved or driven right onto the platform's smooth steel plate. Yet

another useful feature is the rigid base plate on which the scissor-mechanism is mounted. This helps to protect the floor surface and the running rollers, while ensuring jolt-free lifting and providing improved stability. These practical advantages are available as standard in the whole varied range of configurations, with lifting capacities of up to 1,5 metric tons. This lifting table not only leaves no wishes unfulfilled in terms of specifications but also corresponds to all relevant safety standards (e.g. German strict UVV rules).

Lifting Tables



PROLINE & SILVERLINE Low Height Scissors Lifting Tables

The highlights of our low height scissor lifting table

Our offer

- The extremely low-profile design eliminates the cost and effort of installing in a pit
- The practical levelling wedge permits the platform to be approached with a pallet truck or transporter
- Enclosed platform
- The floor plate is gentle on materials and provides for jolt-free lifting and greater stability
- Precise guidance of loads
- Highly efficient
- Safe and reliable to operate
- Integrated pressure control valve for protection against overloading
- Complies with all valid German UVV safety standards

Further options, e.g. higher lifting capacity and alternative platform sizes available on request!

Your advantage

High utility value

High functionality

High standard of safety

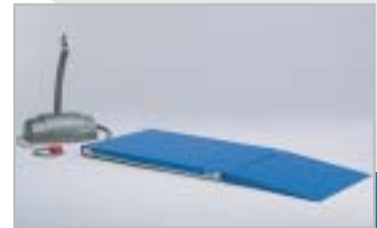

3



Information about optional accessories available on request

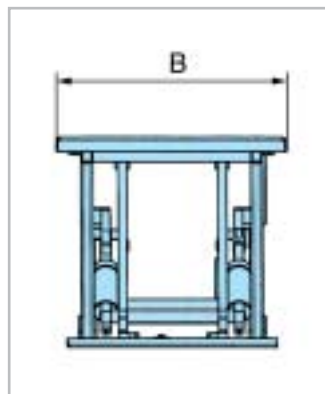
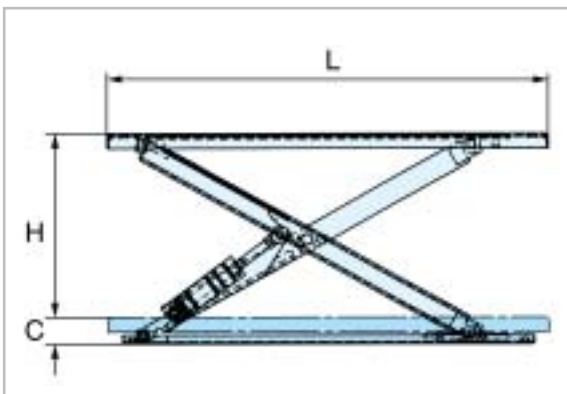

Art. No.	Lifting capacity t	Lift (H) m	Platform (L x B) m	Overall height (C) mm	Lifting time s	Motor power kW	Weight kg
034582031	0,5	0,78	1,40 x 0,8	82	12	0,75	210
034582032	0,5	0,78	1,40 x 1,0	82	12	0,75	220
034582033	0,5	0,78	1,60 x 0,8	82	12	0,75	216
034582034	0,5	0,78	1,60 x 1,0	82	12	0,75	229
034582035	1,0	0,78	1,40 x 0,8	82	18	0,75	238
034582036	1,0	0,78	1,40 x 1,0	82	18	0,75	250
034582037	1,0	0,78	1,60 x 0,8	82	18	0,75	245
034582038	1,0	0,78	1,60 x 1,0	82	18	0,75	258
034582039	1,5	0,75	1,55 x 0,8	92	20	1,1	260
034582040	1,5	0,75	1,55 x 1,0	92	20	1,1	290
034582041	1,5	0,75	1,70 x 0,8	92	20	1,1	270
034582042	1,5	0,75	1,70 x 1,0	92	20	1,1	300



Lifting Tables

SILVERLINE Low Height Scissors Lifting Tables

3



Information about optional accessories available on request

The highlights of our low height scissor lifting table

Our offer

- The ultra-low-profile design eliminates the cost and effort of installing in a pit
- The E-shape and U-shape openings permit convenient loading and loading with a pallet truck
- Ergonomic workstation organization
- Baseframe is gentle on materials and provides for jolt-free lifting and greater stability
- Precision guidance of loads
- Highly efficient
- Safe and reliable to operate
- Integrated pressure control valve for protection against overloading
- Complies with all valid German UVV safety standards

Your advantage

High utility value

High functionality

High standard of safety

When the lifting of loads has to be made as effortless as possible, then you need an ultra-low-profile lifting table in an E-shape or U-shape.



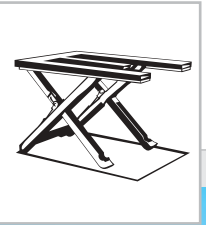

SILVERLINE Low Height Scissors Lifting Tables

silberblau E-TYPE

HTF-XE SILVERLINE for max. 1,5 t

Openings give you have a whole host of practical advantages for everyday work with heavy goods. With the rugged SILVERLINE low height scissor lifting table in an E-shape the smooth steel platform can be loaded with a pallet truck and the pallets then lifted to the required working height without physical strain. The ultra-low-profile design cuts out the cost and effort of installing in a pit. At the same time, it goes without saying that nothing is spared when it comes to the standard Pfaff-silberblau features. For example, overload protection and the baseframe are included as standard. You really should not expect less from a well-conceived solution these days. And you certainly should not have to pay more for it either.

3

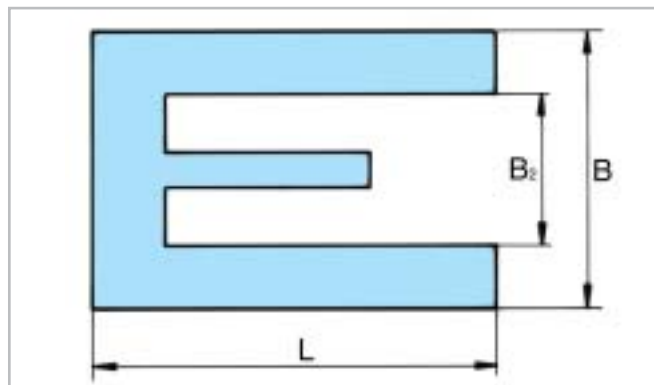
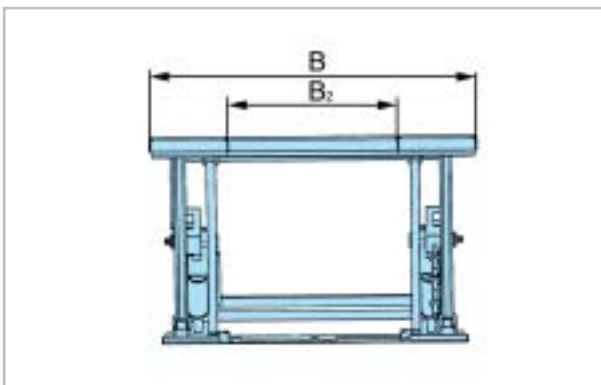
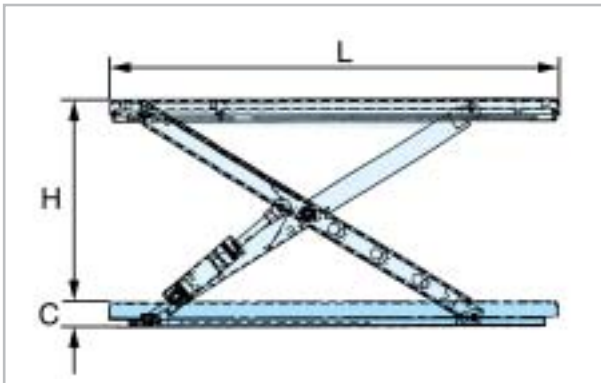

HTF-XE SILVERLINE low height scissor lifting table

Art. No.	Lifting capacity t	Lift (H) m	Platform (L x B) m	Platform (B ₂) clearance mm	Overall height (C) mm	Lifting time s	Motor power kW	Weight kg
034583008	1,0	0,78	1,42 x 1,14	585	80	18	0,75	242
034583009	1,5	0,75	1,55 x 1,16	585	92	20	1,1	298



Lifting Tables

SILVERLINE Low Height Scissors Lifting Tables

silberblau U-TYPE

HTF-XU SILVERLINE for max. 1,5 t

The days when no one had heard of ergonomic workstation organization are long gone and in this connection form has to follow function. Here our heavy-duty SILVERLINE low profile scissor lifting table in a U-shape is highly valued for a diversity of reasons. For example, it enables you to lift heavy pallets and mesh boxes with ease. But that is not all, as it comes with an integrated pressure control valve for extra safety as standard. And for more convenience it has a baseframe beneath the scissors. This protects both the floor and the rollers while providing for jolt-free lifting and greater stability at the same time. And because of its ultra-low-profile design we also keep the price down for you as well.

3

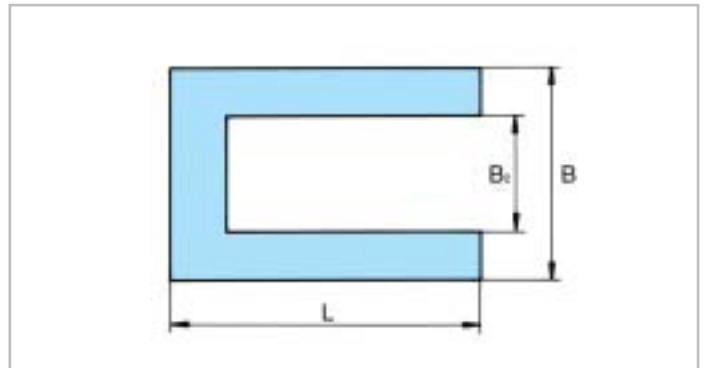
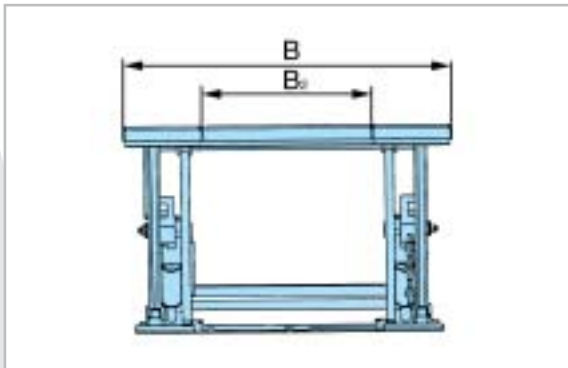
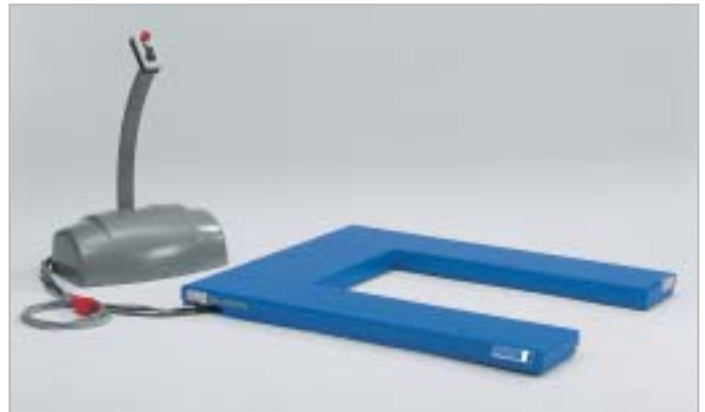
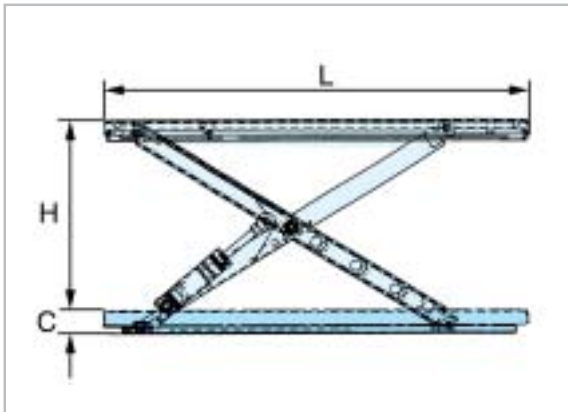

HTF-XU SILVERLINE low height scissor lifting table

Art. No.	Lifting capacity t	Lift (H) m	Platform (L x B) m	Platform (B) clearance mm	Overall height (C) mm	Lifting time s	Motor power kW	Weight kg
034583006	1,0	0,78	1,42 x 1,14	585	80	18	0,75	235
034583007	1,5	0,75	1,55 x 1,16	585	92	20	1,1	290