



Lifting Tables

PROLINE Lifting Tables for Loading Processes

3

This robust equipment for the goods-handling industry is so tough that you can even drive a truck over it. This unit is the ideal firm and safe solution whenever extra convenience is required during effort-saving loading or unloading.

silberblau CLOSEUP

HTV-X PROLINE up to 5t

This space-saving hydraulic loading platform is especially designed for pit installations. Its platform will be level to the ground and is made of rigid, curved stud plate 8 mm thickness. Thus lifting of even heavy loads within loading bays is possible without taking up excessive space. Platform dimensions are carefully designed to allow direct pallet truck access from loading bay to the truck. The cantilever chassis is supplied as standard, avoiding the need for cost and time consuming underpouring after installation. In fact, a whole range of features is included to ensure a long service life: reduced peaks of pressure, cylinder with sealed plunger system, the cylinder and scissor bearings can be lubricated, and the list goes on...

Make your decision for for long-term use of the robust HTV-X PROLINE for lifting capacities of up to 5 tons.



Informationen on optional accessories, please see page 53



PROLINE Lifting Tables for Loading Processes

The highlights of our lifting tables for loading processes

Our offer

- Same cylinder force at start and end position of the platform provides nearly constant lifting speed over the total lift
- None or only low pressure peaks prevent the seal, valve and pump elements against wear.
- Low elasticity/resilience
- Hydraulic cylinder with sealed plunger system
- No corrosion problems due to air-intake
- Cylinder and scissor bearings with lubrication possibility
- Lubricant-filled plain spherical roller bearings
- Ballbearing rollers with permanent lubrication
- The adjustable upper stroke limit switch is protected by being installed under the platform
- The electrical system and integrated control elements are always accessible from the outside
- Corresponds to all relevant safety regulations (e.g. German UVV standards)

Please ask for further options, such as higher lifting capacity or alternative platform sizes!

Your advantage

High level of handling performance

Long service life

High level of safety



3

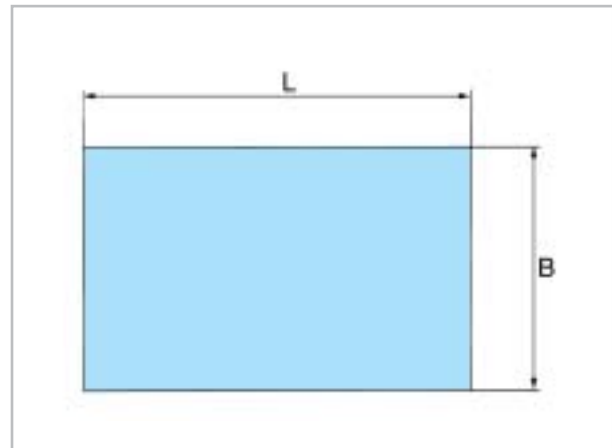
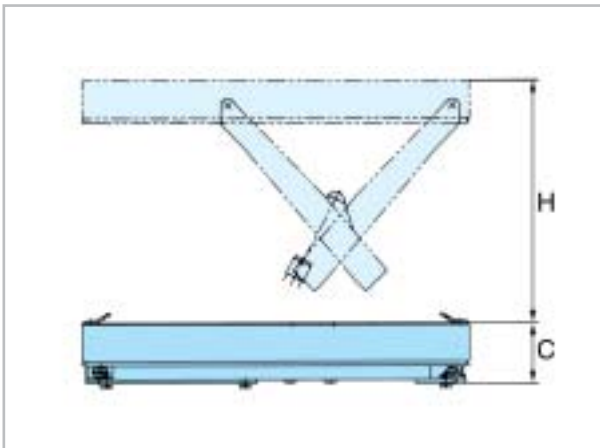

HTV-X PROLINE lifting tables for loading processes

Art. No.	Lifting capacity t	Lift (H) m	Platform (L x B) m	Overall height (C) mm	Lifting time s	Motor power kW	Weight kg
034560050	2,0	1,6	2,50 x 1,6	400	24	3	1735
034560051	2,0	1,6	3,00 x 2,0	400	24	3	2090
034560060	3,0	1,6	2,50 x 1,6	400	24	3	1770
034560061	3,0	1,6	3,00 x 2,0	400	24	3	2130
034560070	4,0	1,6	2,50 x 1,6	400	36	3	1820
034560071	4,0	1,6	3,00 x 2,0	400	36	3	2190
034560080	5,0	1,6	2,50 x 1,6	400	36	3	1860
034560081	5,0	1,6	3,00 x 2,0	400	36	3	2250