



# Material Handling Equipment

## High Lift Pallet Trucks

1



**silverblau** HIGH LINE  
HU 10-XP

### Manual drive and manual lifting

Choosing the HU 10-XP you will get more than just a lifting platform with a 1000 kg lifting capacity for your workshop or production area. The HU 10-XP is designed to be used as a normal hand pallet truck to move palletised loads up to 1000 kg when lifting up 200 mm. With the extremely low apron height of 432 mm the HU 10-XP ensures optimum safety of the load and operator vision at its maximum lift height giving the operator a safe and stable load platform. The quick lift feature of the HU 10-XP warrants minimum operator effort at 23 strokes to the 800 mm lift height.

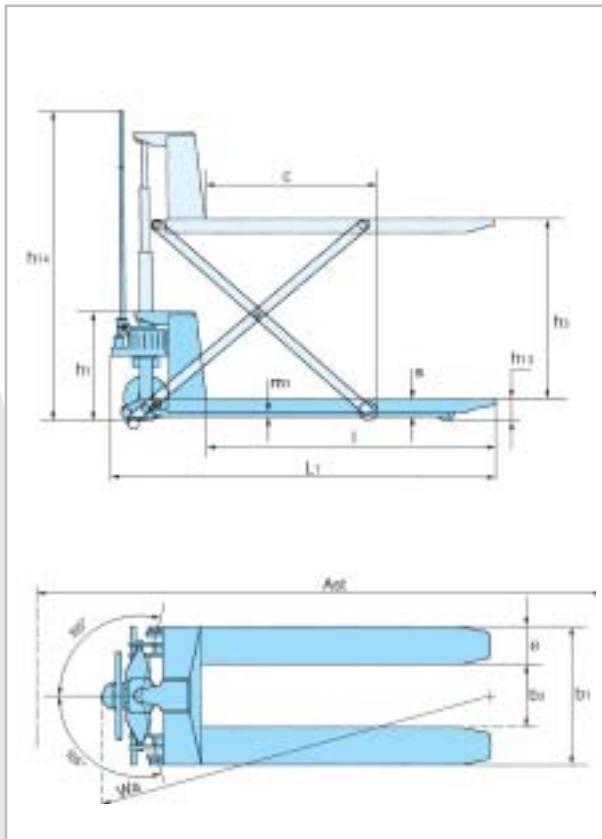

Type		HU 10-XP
Art. No.		034528120
Lifting capacity in t		1,0
Steering-/load wheels*		PUR/PUR
Wheel size front in mm		200x50
Load wheel size rear in mm		78x60
Number of wheels front/rear		2/2
Lifting height in mm	$h_3$	715
Load center in mm	$c$	600
Height of chassis in mm	$h_1$	432
Height of steering handle in mm	$h_{14}$	1240
Height when lowered in mm	$h_{13}$	85
Total length in mm	$L_1$	1535
Fork length in mm	$l$	1170
Fork width in mm	$e$	160
Fork height in mm	$s$	45
Carrying fork width in mm	$b_1$	540
Clear width in mm	$b_3$	220
Floor/Ground clearance in mm	$m_1$	45
Lift per pump stroke		31/12
Quick lift / normal lift in mm		
Aisle width for euro pallets in mm	$A_{st}$	1815
Turning radius in mm	$Wa$	1330
Weight in kg		127

\* Polyurethane (PUR)



## High Lift Pallet Trucks

1



### **silberblau** HIGH LINE COMFORT HU 10-XE

#### Manual drive and electric lifting

The perfect combination of performance and easy maneuvering, quality and robustness. The high lift pallet truck HU 10-XE complies with highest requirements and demonstrates its first-class performance during applications with loads up to 1 ton and lifting heights up to 800 mm. With its stability distance of 630 mm an outstanding frontal safety. With its oversized 12 V pump and 900 watt, record lifting times are reached. Combined with its "inner strength" the HU 10-XE with its standard 540 mm and a fork length of 1170 mm it can be used as a standard hand pallet truck.

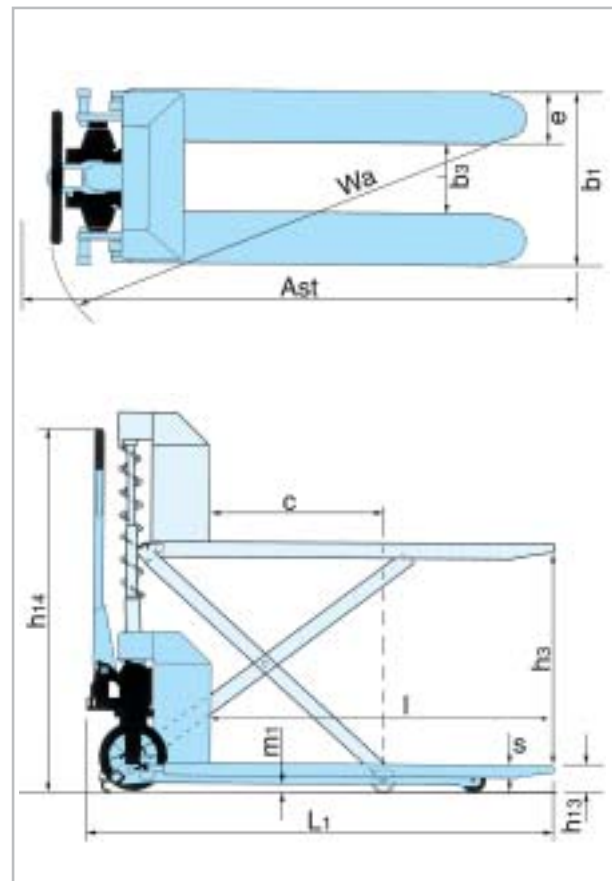

Type		HU 10-XE
Art. No.		040012520
Lifting capacity in t		1,0
Steering-/load wheels*		PUR/PUR
Wheel size front in mm		200x50
Load wheel size rear in mm		78x60
Number of wheels front/rear		2/2
Lifting height in mm	$h_3$	715
Load center in mm	$c$	600
Height of steering handle in mm	$h_{14}$	1240
Height when lowered in mm	$h_{13}$	85
Total length in mm	$L_1$	1575
Fork length in mm	$l$	1170
Fork width in mm	$e$	160
Fork height in mm	$s$	45
Carrying fork width in mm	$b_1$	540
Clear width in mm	$b_3$	220
Floor/ground clearance in mm	$m_1$	45
Lifting time loaded/unloaded in sec		18/16
Aisle width for euro pallets in mm	$Ast$	1815
Turning radius in mm	$Wa$	1330
Weight in kg		172

\* Polyurethane (PUR)