

# Industrial & Workshop Hydraulics

## Workshop Presses

4



HWPHP 15/20,  
30 t plus, with cable winch

### HWPHP Workshop Presses with hand pumps

Reliability makes the difference. Anyone needing a rugged workshop press with hand pump with pressing power of 50 t for repair and assembly work will always turn to the HWPHP. Whether for pressing bearings and bushes in and out, straightening axles, beams and shafts or bending, pressing and setting up tools ...this technology offers the perfect solution. It comes with an automatic piston return, 2-level hand pump, adjustable pick-up table, quick-elevating system and chrome-plated, hardened pistons. The HWPHP press with hand pump has an optimum transmission ratio, meaning that large lifting distances are covered with just a few pump movements.

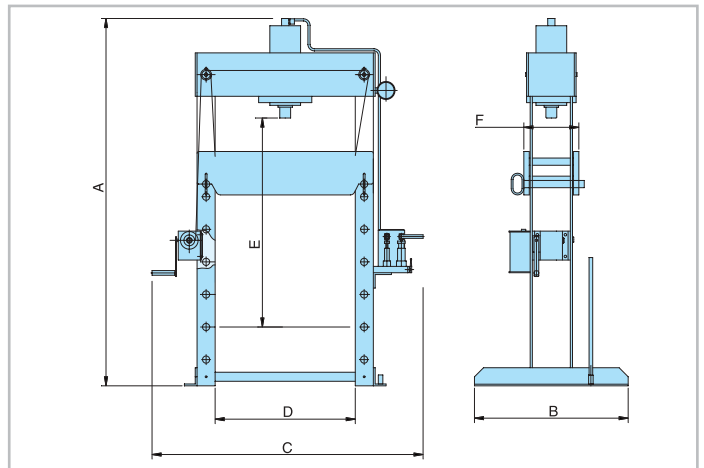

Accessories for HWPHP 15 and 20 t included in delivery items. Other versions available on request.



Prism set



Base plate



Centering device

| Type               |   |     | HWPHP 15  | HWPHP 20  | HWPHP 30  | HWPHP 40  | HWPHP 50  |
|--------------------|---|-----|-----------|-----------|-----------|-----------|-----------|
| Art. No.           |   |     | 040012730 | 040012731 | 040012732 | 040012733 | 040012734 |
| Pressing power     |   | t   | 15        | 20        | 30        | 40        | 50        |
| Operating pressure |   | bar | 240       | 320       | 250       | 330       | 330       |
| Height             | A | mm  | 1870      | 1870      | 1920      | 2010      | 2030      |
| Depth              | B | mm  | 500       | 500       | 600       | 780       | 850       |
| Width              | C | mm  | 940       | 940       | 1260      | 1335      | 1350      |
| Clear width        | D | mm  | 550       | 550       | 700       | 775       | 775       |
| Clear height       | E | mm  | 940       | 940       | 1000      | 1125      | 1155      |
| Depth of frame     | F | mm  | 185       | 185       | 245       | 258       | 304       |
| Lift               |   | mm  | 190       | 190       | 190       | 190       | 190       |
| Unladen weight     |   | kg  | 150       | 150       | 250       | 310       | 420       |

Intended use: A workshop press/straightening press is a press which has a slow closing speed of 10 mm/second and a maximum pressing capacity of 10 full load/full lift presses per hour.

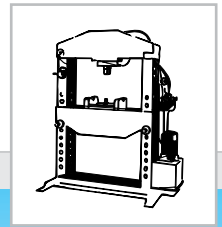

## Workshop Presses

### HWPEP Workshop Presses with electric pumps

Compressed productivity in press form for repair and assembly work. This is what the workshop press offers with its reliable 1- or 2-level electric pump and pressing power of up to 100 metric tons. Whether you are pressing bearings and bushes in and out, straightening axles, beams and shafts, or bending, pressing or setting up tools ... the high performance of this press is based on optimized technology. For example, the press comes with a high pressure unit with a manometer, a control valve and three-way valve, an adjustable pick-up table and high-quality pistons made of chrome-plated hardened and tempered special steel.

Accessories available as options (see page 68)



HWPEP-1 50



Detail of cable winch

4

#### Workshop press – with 1-level electric pump

| Type               |   |        | HWPEP-1 30   | HWPEP-1 40 | HWPEP-1 50 | HWPEP-1 100 |
|--------------------|---|--------|--------------|------------|------------|-------------|
| Art. No.           |   |        | 040012735    | 040012736  | 040012737  | 040012738   |
| Pressing power     |   | t      | 30           | 40         | 50         | 100         |
| Operating pressure |   | bar    | 250          | 330        | 330        | 320         |
| Height             | A | mm     | 1920         | 2010       | 2030       | 2170        |
| Depth              | B | mm     | 660          | 780        | 850        | 1000        |
| Width              | C | mm     | 1240         | 1315       | 1410       | 1700        |
| Clear width        | D | mm     | 700          | 775        | 775        | 1000        |
| Clear height       | E | mm     | 1000         | 1125       | 1155       | 1075        |
| Depth of frame     | F | mm     | 245          | 258        | 300        | 415         |
| Lift               |   | mm     | 260          | 260        | 260        | 300         |
| Lifting speed      |   | mm/min | 306          | 306        | 246        | 174         |
| Motor data         |   |        | 400 V 1,5 kW |            |            | 400 V 3 kW  |
| Load factor        |   |        | S3-30%*      |            |            |             |
| Unladen weight     |   | kg     | 280          | 340        | 450        | 920         |

#### Workshop press – with 2-level electric pump

| Type               |   |        | HWPEP-2 30   | HWPEP-2 40 | HWPEP-2 50 | HWPEP-2 100 |
|--------------------|---|--------|--------------|------------|------------|-------------|
| Art. No.           |   |        | 040012739    | 040012740  | 040012741  | 040012742   |
| Pressing power     |   | t      | 30           | 40         | 50         | 100         |
| Operating pressure |   | bar    | 250          | 330        | 330        | 320         |
| Height             | A | mm     | 1920         | 2010       | 2030       | 2170        |
| Depth              | B | mm     | 660          | 780        | 850        | 1000        |
| Width              | C | mm     | 1240         | 1315       | 1460       | 1700        |
| Clear width        | D | mm     | 700          | 775        | 775        | 1000        |
| Clear height       | E | mm     | 1000         | 1125       | 1155       | 1075        |
| Depth of frame     | F | mm     | 245          | 258        | 300        | 415         |
| Lift               |   | mm     | 260          | 260        | 260        | 300         |
| Lifting speed:     |   |        |              |            |            |             |
| Level 1            |   | mm/min | 1296         | 1296       | 1500       | 1464        |
| Lifting speed:     |   |        |              |            |            |             |
| Level 2            |   | mm/min | 252          | 252        | 204        | 174         |
| Motor data         |   |        | 400 V 2,2 kW |            |            | 400 V 3 kW  |
| Load factor        |   |        | S3-30%*      |            |            |             |
| Unladen weight     |   | kg     | 280          | 340        | 450        | 920         |

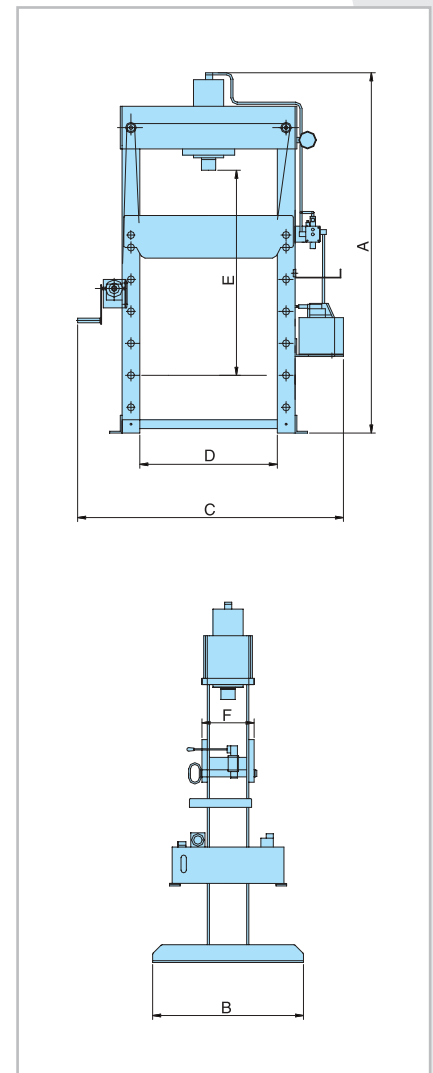

\*10 lifting cycles per hour; max. 6 sec. with pressure control valve for each lifting cycle  
Intended use: A workshop press/straightening press is a press with a slow closing speed of 10 mm/ and a maximum pressing capacity of 10 full load/full lift presses per hour.