

Industrial & Workshop Hydraulics

Workshop Crane SILVERLINE

SILVERLINE HWK KLS Workshop Crane

Power really can be this comfortable. When adaptability is required, the HWK KLS workshop crane is the master of versatility. In both versions for either 0,5 t or 1,0 t lifting capacity, both with a parallel or V-shaped chassis, you have a device to cope with every conceivable workshop requirement. The rotatable hydraulic system provides for absolute operating convenience even in confined spaces. Moreover, the pump raises the cantilever arm to a height of 2080 mm in overdrive with just 30 pump movements. And it does all this with the utmost safety, thanks to the specially designed chassis and the parking wheel brake supplied as standard which hold the crane firmly in position. Once the job has been completed the crane can be quickly and easily folded together and stored away again by just one person.

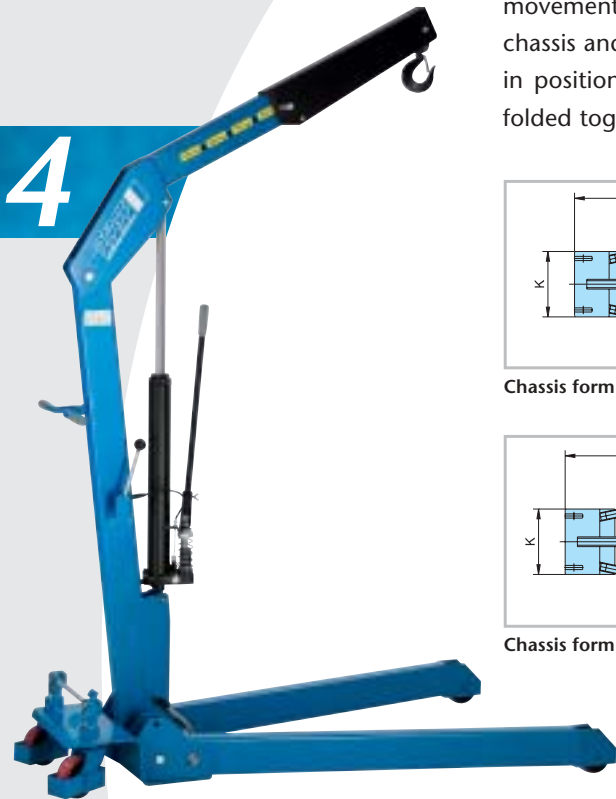

4

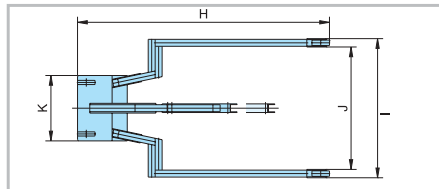

Chassis form II

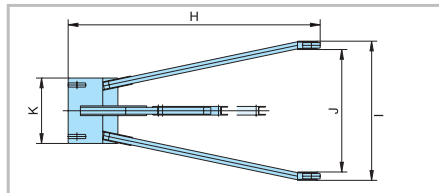

Chassis form V

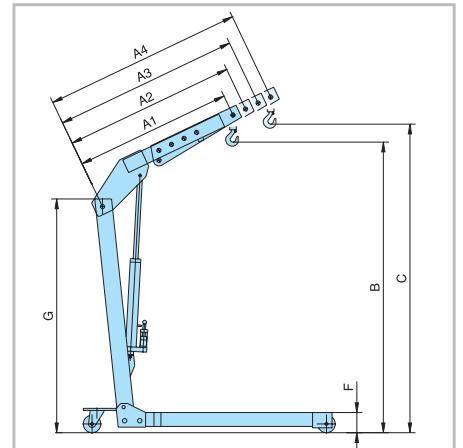

Type			HWK KLS 0,5 040008514	HWK KLS 0,5 040008515	HWK KLS 1,0 040008516	HWK KLS 1,0 040008517
Art. No.						
Chassis form			II	V	II	V
Total cantilever arm length		mm	1430	1430	1430	1430
Admissible load for crane arm length	A1	kg/mm	500/1130	500/1130	1000/1130	1000/1130
	A2	kg/mm	400/1230	400/1230	800/1230	800/1230
	A3	kg/mm	350/1330	350/1330	700/1330	700/1330
	A4	kg/mm	250/1430	250/1430	500/1430	500/1430
Max. hook height with cantilever arm in/out	B/C	mm	2080/2200	2080/2200	2080/2200	2080/2200
Underclearance height	F	mm	160	160	160	160
Drive-through height with cantilever arm lowered	G	mm	1680	1680	1680	1680
Chassis length incl. wheels	H	mm	1820	1820	1820	1820
Chassis width:						
	External/internal	I/J	mm	990/850	990/850	990/850
Rear width	K	mm	620	620	620	620
Hand power for nominal load		daN	16	16	32	32
Lift per pump movement (with load/without load)		mm	90/30	90/30	90/30	90/30
Unladen weight		kg	150	150	150	150