

PFAFF
silberblau
antriebstechnik



**ALS –
Electromechanical
Screw Rams**

ALS – Electromechanical Screw Rams

Electromechanical Screw Rams



The "ALS" Electromechanical Screw Ram is a universal drive system for a wide range of applications within the machine building industry. With a choice of 4 sizes, a modular design in

- "ALS" compact version and
- "ALSR" cylinder version

it is possible to obtain the optimal design features to suit your specific requirements. The system is particularly ideal for single drive applications on linear motion projects.

Description of the product

The "ALS" consists of a fully enclosed housing unit with a rugged axial and radial bearing arrangement and long-term lubrication (low-maintenance). The housing is surface-treated and can be converted into a swivelling version by means of 2 pins. The standard version has a self-locking trapezoidal screw with a travelling nut and a drive shaft for mounting a suitable gear motor. The "ALSR" version consists of the "ALS" standard version plus a fully enclosed shaft and piston structure, with the tubes protected against corrosion. Countless motor options are possible using a choice of mounting flanges or bell housings and couplings. A ball screw with various nut assemblies can also be used instead of the trapezoidal screw.

To complete the product, there is a wide range of accessories such as stroke limiting devices, anti-turn devices and a choice of head types.

Design features

- Maximum dynamic axial force of size
10 = 12,5 kN, 25 = 25 kN,
50 = 50 kN, 100 = 100 kN
- Lifting speeds from 0.5 m/min to 10 m/min depending on the load and cyclic duration factor
- Self-locking trapezoidal screw
- Mounting possibility of every flange-fitting gear motor of solid or hollow shaft design
- Long-term lubrication by high-quality grease and enclosed design
- Standard or stroke lengths to customer's specification based on buckling and speed diagrams
- Special screw diameters and pitches possible
- Wide range of accessories
- Standard stroke lengths "ALS" for size
10: 100/200/300/400 mm
25: 100/200/300/400/500 mm
50: 200/400/600/800/1000 mm
100: 300/600/900/1200/1500 mm
or lengths to order
- Electronic synchronization of several individual drives



Can be used in accordance with EC Directive 94/9/EC (ATEX)

Applications for low cost solution "ALS" drive units

- Feed drives for horizontal or vertical movements in machine building industry and plant construction
- Linear adjustment movements for automation of handling and automobile industry and in building management systems
- Drive units in lock gates and sewage farms with the fully enclosed "ALSR" version providing special protection for the drive unit against contamination
- These benefits can also be used for applications in the food industry and for all outdoor applications
- Applications in aerospace, crane manufacture, paper industry etc.

And soon for your applications as well!



Trapezoidal and ball screw threads

The trapezoidal screw thread design is used for low lifting speeds (up to approx. 3 m/min), low duty cycle values (approx. 20 % per hour) and where lubrication is possible. Ball screw threads are used for very frequent adjustment movements, high lifting speeds and also in extraordinary operating conditions.



Anti-turn device

If the screws do not have an anti-turn device on their own or provided by customer, an integral anti-turn device can be provided using the shaft tube of the "ALSR" version.



Various head designs

The thrust tube of the "ALSR" version can be fitted with a range of head designs. The picture shows a rod-type head (head version IV). Other versions such as heads I and II and a coupling rod that complies with DIN are available as standard (see dimension tables).



Stroke limitation

The "ALSR" version can be fitted with a stroke limitation to order. The picture shows an inductive version using an inductive proximity switch in a programmable D.C. version (10–55V – IP 67) with a simple connection (cable with plug).



"ALS" version

The basic "ALS" version with the standard housing and integral axial and radial bearings can be fitted with a series of gear motors from various manufacturers using different mounting flanges.

ALS – Electromechanical Screw Rams

Selection table	Trapezoidal screw (Tr)							Ball screw (Ku)				
		10	25	50		100		10	25	50	100	
Size ALS – ALSR												
Max. tensile / compressive force	[kN]	12,5	25	50		100		12,5	25	50	100	
Screw		Tr 24x5	Tr 30x6	Tr 40x7	Tr 50x8	Tr 70x12	Tr 80x14	Ku 25x5 / 10	Ku 32x10 / 20	Ku 40x10 / 20	Ku 63x10 / 20	
Static load rating	[kN]	50*	98*	173*		300*		33,8**	99 / 50**	170 / 85**	300 / 219**	
Dynamic load rating	[kN]	28*	46,5*	88*		137*		16,9**	44 / 27,5**	79 / 48**	163 / 75**	
Lift per revolution	[mm/U]	5	6	7	8	12	14	5 / 10	10 / 20	10 / 20	10 / 20	
Max. drive power at 20 °C ambient temp. and 20 % c.d.f.***/hour	[kW]	0,75	1,1	1,5	2,2	4,0	5,5	see service life calculation [A restriction does not exist based on duty cycle (% duty cycle/hour)]				
Max. drive power at 20 °C ambient temp. and 10 % c.d.f.***/hour	[kW]	1,1	1,5	2,0	3,0	5,5	7,5					
Overall efficiency	[%]	34,4	35	32,5	30,5	31,5	32,5	78,0	75,0	75,0	75,0	
Torque-power-speed at 20 % c.d.f.***/hour and 20 °C		see performance data tables							see performance data tables			
Torque at the drive shaft	[Nm]	see performance data tables							11,25 / 22,5	45 / 90	90 / 180	180 / 360
Max. perm. screw length under compr. load	[mm]	see buckling diagram							see buckling diagram			
Max. perm. screw length	[mm]	see speed diagram							see speed diagram			
Housing material		"steel burnished"							"steel burnished"			
Basic weight	[kg]	4,5	10	25		35		4,5	10	25	35	
Extra weight of ALS per 100 mm stroke	[kg]	0,35	0,5	0,8	1,2	2,5	3	0,4	0,5	1	2,5	
Extra weight of ALSR per 100 mm stroke	[kg]	1,3	2,2	4	4,5	9	9,5	1,3	2,2	4,2	9	

* Axial bearing ** Ball screw/nut *** Cyclic duration factor

Buckling diagram

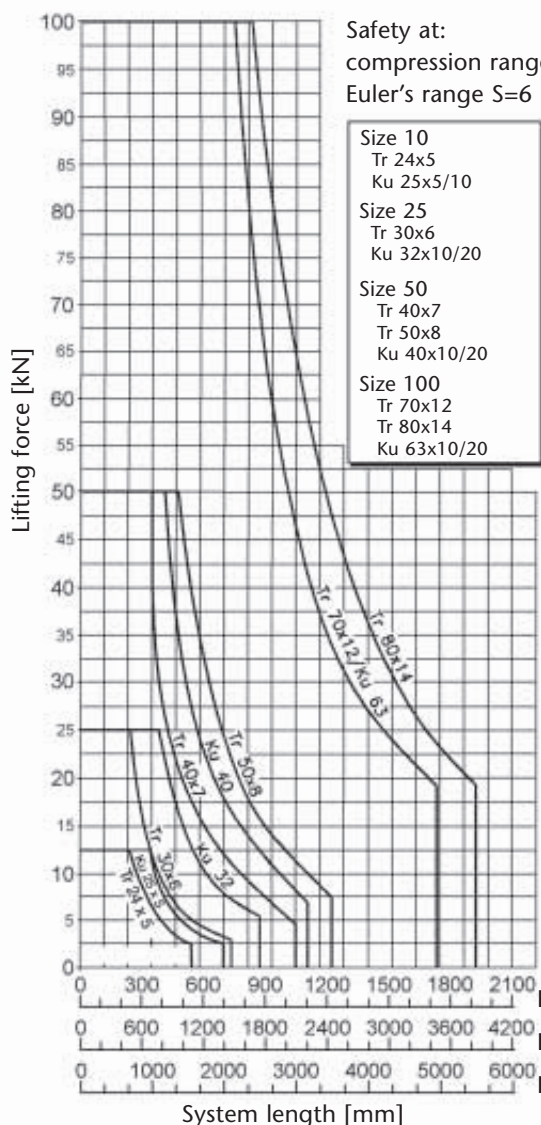

Safety at:
compression range S=4,
Euler's range S=6

Size 10
Tr 24x5
Ku 25x5/10
Size 25
Tr 30x6
Ku 32x10/20
Size 50
Tr 40x7
Tr 50x8
Ku 40x10/20
Size 100
Tr 70x12
Tr 80x14
Ku 63x10/20

Euler's case I

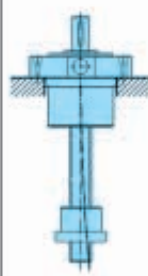

System length = NL + H

Euler's case II

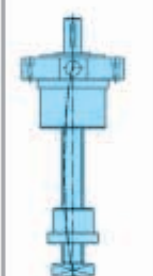

System length = NL + H + C

Euler's case III

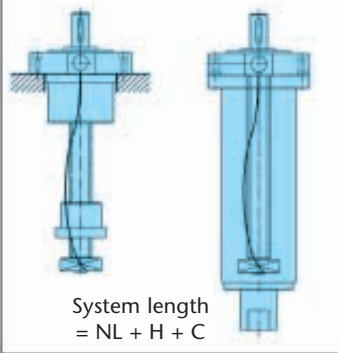

System length = NL + H + C

Speed diagram

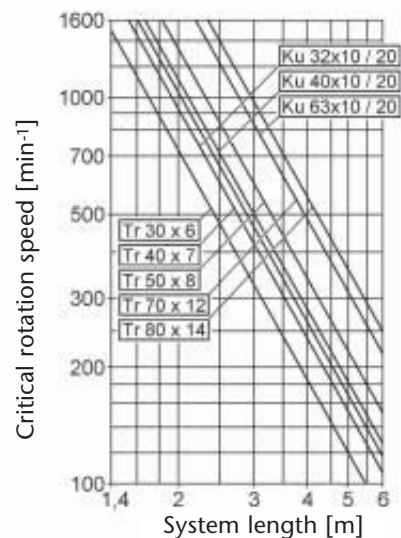

Fixing method 1)

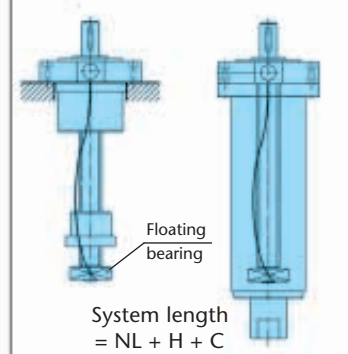

System length = NL + H + C

1) With no floating bearing at the end of the screw, the critical rotation speed is reduced by approx. 80%.

Selection and Sizing

- Look into the selection table for the maximum permissible tensile/compressive forces to narrow down the choice of size
- For compressive force: Check the screw size in the buckling diagram (consider the Euler's case)
- Screw lengths from 1400 mm: Check the screw size in the speed diagram (consider the fixing method)
- Determine the size by looking into the performance data tables (consider the lifting load, speed and cyclic duty factor)
- Check the service life of the bearing and ball screw (use the calculation formula)



Calculation formula

- Drive power

$$P_{\text{eff}} = \frac{F_{\text{dyn}} \cdot v}{60 \cdot \eta} \text{ [kW]}$$

- Service life

$$L_h = \frac{1 \cdot 10^6}{60 \cdot n} \cdot \left(\frac{C_{\text{dyn}}}{F_{\text{dyn}}} \right)^3 \text{ [Hours]}$$

F_{dyn} = lifting load [kN]

v = lifting speed [m/min]

η = overall efficiency

n = input speed [min⁻¹]

C_{dyn} = dynamic load rating [kN]

Performance tables for version with trapezoidal screws only

(due to the heat generated in the screw/nut).

All performance figures related to the dynamic lifting force and a duty cycle of 20 % per hour or 30 % per 10 minutes in an ambient temperature of 20 °C. The screw/nut system will overheat in the boxes shaded in gray. The design of the version with ball screws is based on the service life according to above formula.

Performance data table ALS 10 – ALSR 10 with Tr 24x5

Speed n [min ⁻¹]	Lifting Speed Tr 24x5 [m/min]	12,5 kN Tr 24x5		10 kN Tr 24x5		7,5 kN Tr 24x5		5 kN Tr 24x5		2,5 kN Tr 24x5	
		Nm	kW	Nm	kW	Nm	kW	Nm	kW	Nm	kW
750	3,75	28,8	2,26	23,07	1,81	17,30	1,36	11,53	0,91	5,77	0,45
500	2,5	28,8	1,51	23,07	1,21	17,30	0,91	11,53	0,60	5,77	0,30
250	1,25	28,8	0,75	23,07	0,60	17,30	0,45	11,53	0,30	5,77	0,15
100	0,5	28,8	0,30	23,07	0,24	17,30	0,18	11,53	0,12	5,77	0,10
50	0,25	28,8	0,15	23,07	0,12	17,30	0,09	11,53	0,10	5,77	0,1

Performance data table ALS 25 – ALSR 25 with Tr 30x6

Speed n [min ⁻¹]	Lifting Speed Tr 30x6 [m/min]	25 kN Tr 30x6		20 kN Tr 30x6		15 kN Tr 30x6		10 kN Tr 30x6		5 kN Tr 30x6	
		Nm	kW	Nm	kW	Nm	kW	Nm	kW	Nm	kW
700	4,20	70	5,2	56	4,1	42	3,1	28	2,1	14	1,0
500	3,00	70	3,7	56	2,9	42	2,2	28	1,5	14	0,7
300	1,80	70	2,2	56	1,8	42	1,3	28	0,9	14	0,4
100	0,60	70	0,7	56	0,6	42	0,4	28	0,3	14	0,1
50	0,30	70	0,4	56	0,3	42	0,2	28	0,1	14	0,1

Performance data table ALS 50 – ALSR 50 with Tr 40x7 / Tr 50x8

Speed n [min ⁻¹]	Lifting Speed Tr 40x7 / Tr 50x8		50 kN		40 kN		30 kN		25 kN		20 kN		10 kN	
	Tr 40x7	Tr 50x8	Tr 40x7	Tr 50x8	Tr 40x7	Tr 50x8	Tr 40x7	Tr 50x8	Tr 40x7	Tr 50x8	Tr 40x7	Tr 50x8	Tr 40x7	Tr 50x8
500	3,50	4,00	180	9,4	218	11,4	144	7,5	174	9,1	108	5,6	131	6,8
400	2,80	3,20	180	7,5	218	9,1	144	6,0	174	7,3	108	4,5	131	5,5
300	2,10	2,40	180	5,6	218	6,8	144	4,5	174	5,5	108	3,4	131	4,1
100	0,70	0,80	180	1,9	218	2,3	144	1,5	174	1,8	108	1,1	131	1,4
50	0,35	0,40	180	0,9	218	1,1	144	0,8	174	0,9	108	0,6	131	0,7

Performance data table ALS 100 – ALSR 100 with Tr 70x12 / Tr 80x14

Speed n [min ⁻¹]	Lifting Speed Tr 70x12 / Tr 80x14		100 kN		80 kN		60 kN		50 kN		40 kN		20 kN		10 kN															
	Tr 70x12	Tr 80x14	Tr 70x12	Tr 80x14	Tr 70x12	Tr 80x14	Tr 70x12	Tr 80x14	Tr 70x12	Tr 80x14	Tr 70x12	Tr 80x14	Tr 70x12	Tr 80x14	Tr 70x12	Tr 80x14														
225	2,70	3,15	624	14,7	719	16,9	499	11,8	575	13,5	375	8,8	431	10,2	312	7,4	359	8,5	250	5,9	288	6,8	125	2,9	144	3,4	62	1,5	72	1,7
200	2,40	2,80	624	13,1	719	15,1	499	10,5	575	12,0	375	7,8	431	9,0	312	6,5	359	7,5	250	5,2	288	6,0	125	2,6	144	3,0	62	1,3	72	1,5
160	1,92	2,24	624	10,5	719	12,0	499	8,4	575	9,6	375	6,3	431	7,2	312	5,2	359	6,0	250	4,2	288	4,8	125	2,1	144	2,4	62	1,0	72	1,2
80	0,96	1,12	624	5,2	719	6,0	499	4,2	575	4,8	375	3,1	431	3,6	312	2,6	359	3,0	250	2,1	288	2,4	125	1,0	144	1,2	62	0,5	72	0,6
40	0,48	0,56	624	2,6	719	3,0	499	2,1	575	2,4	375	1,6	431	1,8	312	1,3	359	1,5	250	1,0	288	1,2	125	0,5	144	0,6	62	0,3	72	0,3

Dimension	ALS 10 - ALSR 10			ALS 25 - ALSR 25			ALS 50 - ALSR 50			ALS 100 - ALSR 100			
	Tr screw	Ball screw		Tr screw	Ball screw		Tr screw	Ball screw		Tr screw	Ball screw		
	Tr 24x5	Ku 25x5	Ku 25x10	Tr 30x6	Ku 32x10	Ku 32x20	Tr 40x7	Tr 50x8	Ku 40x10	Ku 40x20	Tr 70x12	Tr 80x14	Ku 63x10
Ø A		100			145			175				250	
Ø B j6		60			95			110				180	
C		24			34			38				52	
C 1		12			17			19				26	
C 3		30			40			47				61	
Ø D j6		16			25			30				40	
E ± 0,2		82			125			155				215	
F		2			3			4				5	
G		16			13			15				25	
H		56			63			85				111	
h		20			40			63				54	
i		M 33x2			M 42x2			M 60x2				M 95x3	
K 1		8 x 45 °			8 x 45 °			6 x 60 °				8 x 45 °	
K 2		4 x 90 °			4 x 90 °			6 x 60 °				4 x 90 °	
L		40			50			60				90	
Ø M f7		60			90			115				150	
Ø M 1		70			100			130				170	
N		68			88			106				150	
N 1		6,6			8			6				8	
N 2		4			4			6				6	
NL / Stroke	+85	+91	+96	+85	+130	+170	+120	+176	+191	+205	+198	+238	
Ø P		59,5			89,5			114				149	
Ø P 1		40			50			70				110	
Q		5 x 5 x 20			8 x 7 x 40			8 x 7 x 50				12 x 8 x 80	
R 1		22,5 °			22,5 °			30 °				22,5 °	
R 2		45 °			45 °			15 °				45 °	
S	205	211	216	236	281	321	311	342	407	466	459	499	
S 1- DIN 912/8.8		M6			M8			M8				M12	
S 2- DIN 912/8.8		M6			M8			M8				M12	
S 5		225			276			336				486	
S 6		245			298			374				514	
S 7		282			343			429				569	
S 8		285			343			439				601	
S 9		45			55			73				170	
S 10		90			100			124				171	
T		10			23			25				42	
U		90			140 -0,3			170 -0,3				240 -0,4	
V		M6			M8			M10				M12x1	
Ø W H7		16			20			25				35	
X		20		20	40	60	30	50	70	40	50	70	

Travelling Nut												
a	45	51	56	45	50	60	76	51	125	116	110	
b		10		15	12	18	14		30	20		
Ø c	35 h9	40 g6		50 h9	50 g6	70 h9	63 g6		120 h9	95 g6		
Ø d	50	62		80		87	93		155	135		
Ø tk	-	51		-	65	-	78		-	115		
Ø s	-	6,6		-	9	-	9		-	13,5		

Head Type I													
Ø a		15 j6			20 j6			30 j6				50 k6	
b		24			30			50				60	

Head Type II													
Ø d		72			98			122				182	
Ø e		50			75			85				135	
Ø f		9			14			17				26	
r		10			12			18				25	

Head Type IV													
l -0,2		25			30			40				75	
n		40			50			70				120	
Ø o H7		20			25			35				60	
u		40			50			65				110	
v		20			25			35				60	

Trunnion Pins													
Z		136			200			250				330	

Pillow Blocks													
a		60			80			100				140	
b		9			12			20				25	
c		75			100			125				170	
d		45			60			75				100	
f		45			60			95				130	
g		15			20			25				30	
h		75			100			140				200	
Ø j		13			17			21				25	
k		150			230			270				370	
m		180			260			320				440	

IEC Flange													
Ø A 2		120			150			175				250	
Ø B 2 H7		80			110			110				180	
Ø C 2		20			12			17				25	
Ø E ±0,2		100			130			130				215	
S 3-DIN 6912/8.8		M6			M8			M8				M8	



PFaff
silberblau

hebezeuge & fördergeräte

**Lifting & Material Handling
Equipment**



PFaff
silberblau

antriebstechnik

Actuator Technology



PFaff
silberblau

verkehrstechnik

Rail Technology



ALLTEC
antriebstechnik

www.alltec.de

Pfaff-silberblau
Hebezeugfabrik GmbH & Co. KG
Äußere Industriestraße 18
86316 Friedberg / GERMANY
Phone +49 / 8 21 / 78 01-0
Fax +49 / 8 21 / 78 01-299



Reg.No. 054 396 QM

